

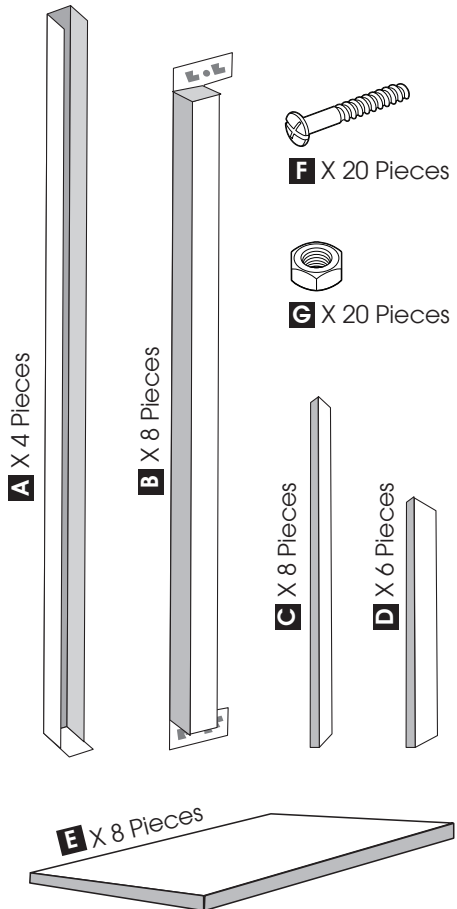

LONG SPAN SHELVING UNIT MSU2020 Instruction Manual

Parts List



1 X 2

Bolt the Straight Cross Brace **D** and Diagonal Cross Brace **C** using Bolts **F** and Nut **G** into the Upright Legs **A**. Skip a hole between the Centre Straight Cross Brace and the top Diagonal Cross Brace.

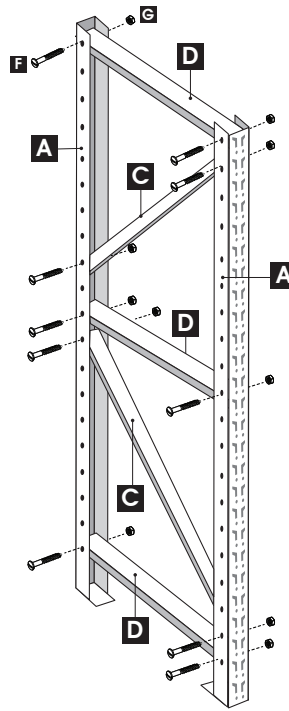

2

Slide the Cross Beams **B** into the Slots on the Upright Legs **A**. Press Down to Engage Slots.

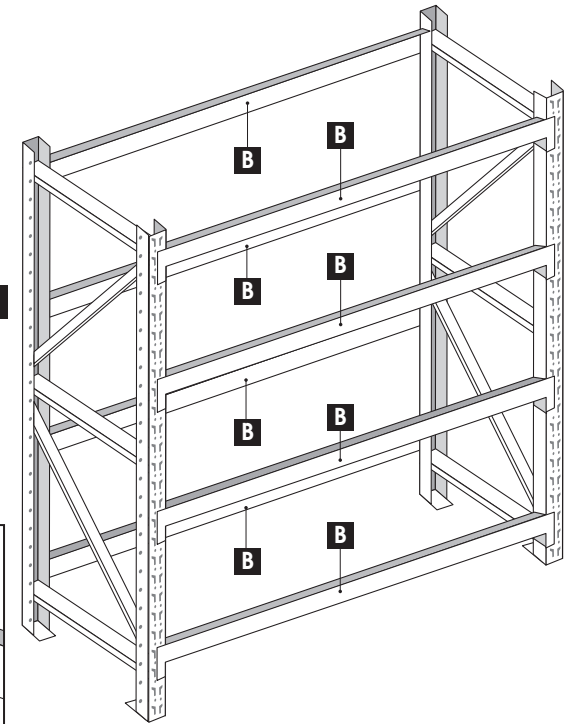
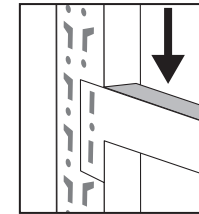

3

Place 2 Inserts **E** Per Shelf on to the Rails on the Cross Beams **B**.

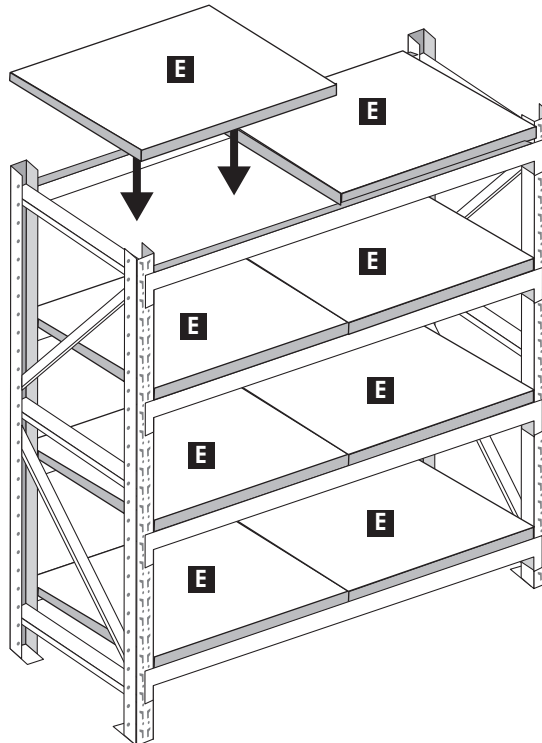

4

**WARNING
RISK OF TIPPING**

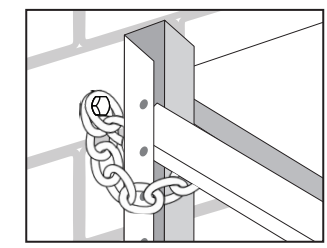

It is recommended to always secure your shelving to the wall with chain. There are different chains, screws and anchors available from Paramount Browns for different wall types and fixing points. *(Chain and Fasteners are not included)*

Position on a Flat & Level Surface Before Loading